

# HANDPROTEKTOR

Hand guard | Protectores de manos | Protège-mains | Paramani

Art.-Nr: 90385-00X

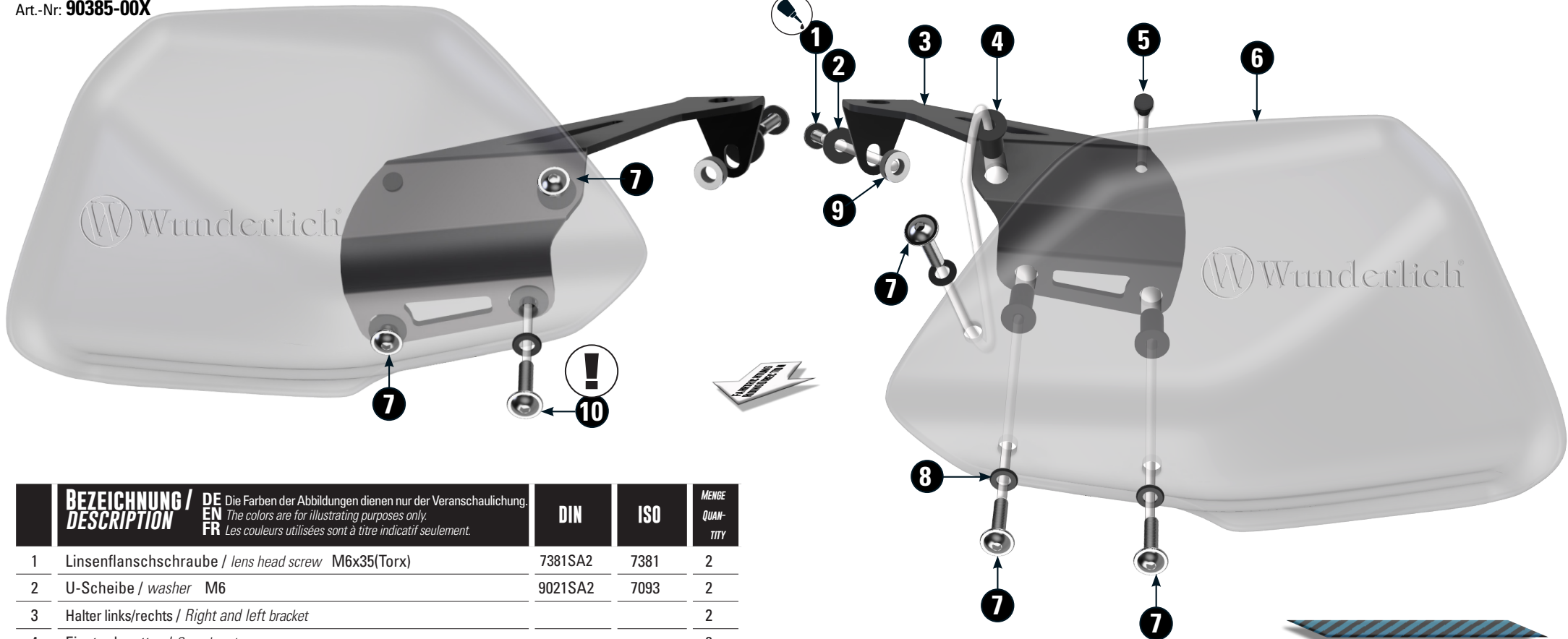

BEZEICHNUNG / DESCRIPTION	DE EN FR	Die Farben der Abbildungen dienen nur der Veranschaulichung. The colors are for illustrating purposes only. Les couleurs utilisées sont à titre indicatif seulement.	DIN	ISO	MENGE QUAN- TITY
1	Linsenflanschschraube / lens head screw	M6x35(Torx)	7381SA2	7381	2
2	U-Scheibe / washer	M6	9021SA2	7093	2
3	Halter links/rechts / Right and left bracket				2
4	Einsteckmutter / Speed nut				6
5	Gummistopfen / Rubber stoper				2
6	Handprotektor link/rechts / Right and left hand guard				2
7	Linsenflanschschraube / lens head screw	M5x20(Torx)	7381SA2	7381SA2	5
8	U-Scheibe KST / Washer plastic	M5	125KST	7089	6
9	Hülse / sleeve	ØD 12,0 - Ød 6,5 - h 4,0mm			2
10	Linsenflanschschraube / Lens head screw	M5x16(Torx)	7381SA2	7381SA2	1
11	Gummi selbstkleben / Self-adhesive rubber				2
12	Schraubensicherung / Thread locking fluid				1

## LEGENDE / Key/ file Légende

- Anbau Tipp**  
Fitting tip  
Astuce de montage
- Achtung**  
Attention  
Attention
- Vergrößerung**  
Magnification  
Grossissement
- Montagepaste**  
Fitting lubricant  
Lubrifiant de montage

- Zusammenbau**  
Assembly  
Montage
- Schraubensicherung**  
Thread locking fluid  
Freinfilets
- Drehmoment**  
Torque  
Torque
- Reiniger**  
Cleaner  
Nettoyant

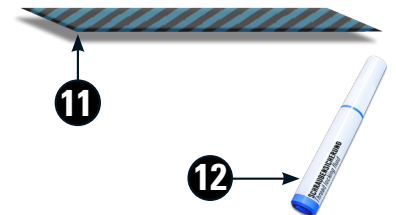

10.04.2026



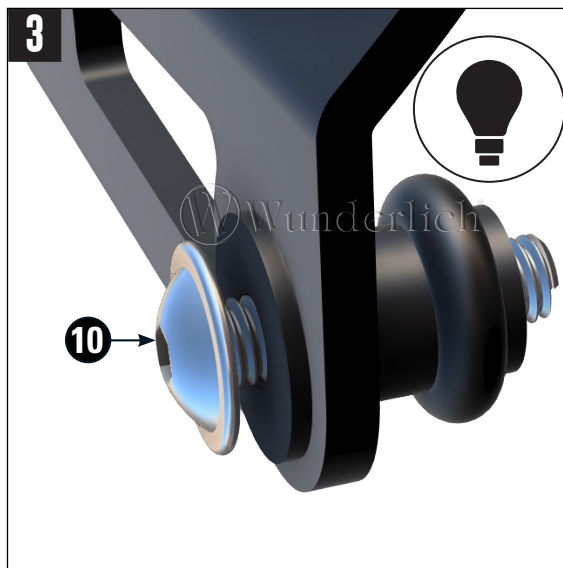
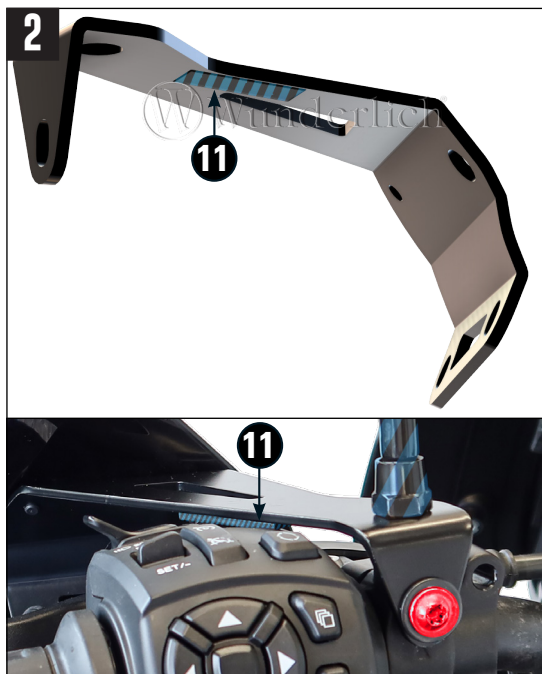
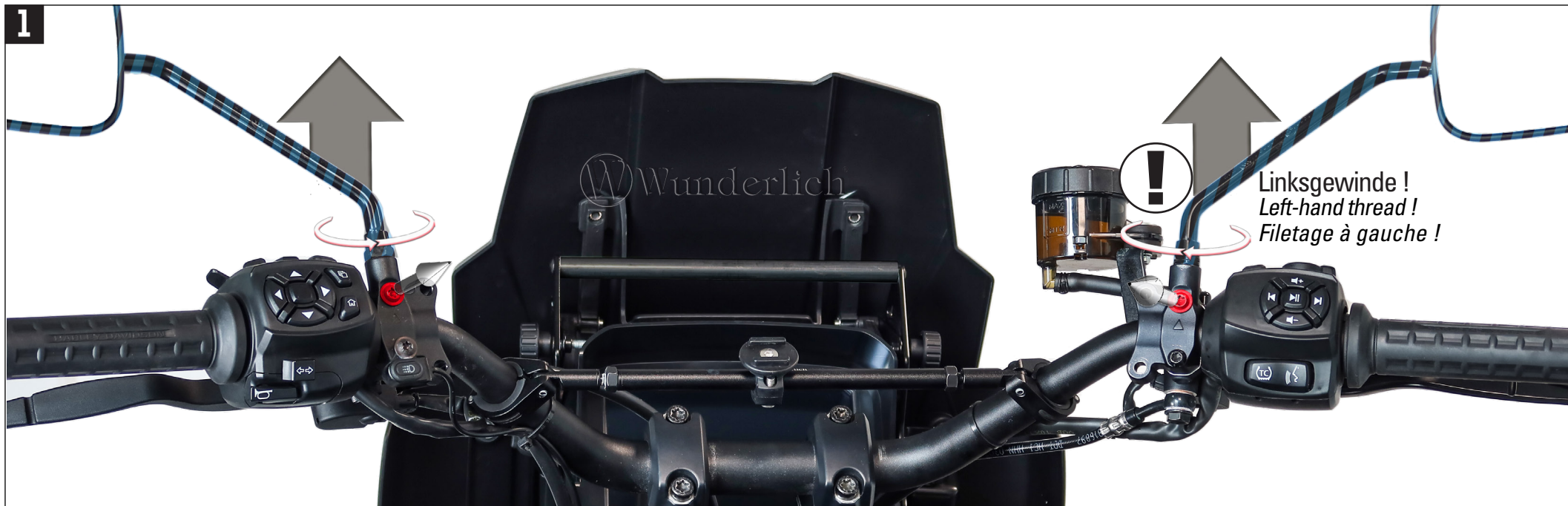

**Einsteckmutter 1x ohne Protektor anziehen.**  
*Tighten the speed nut 1x without protector.*  
*Serrer l'écrou de vitesse 1x sans protecteur.*

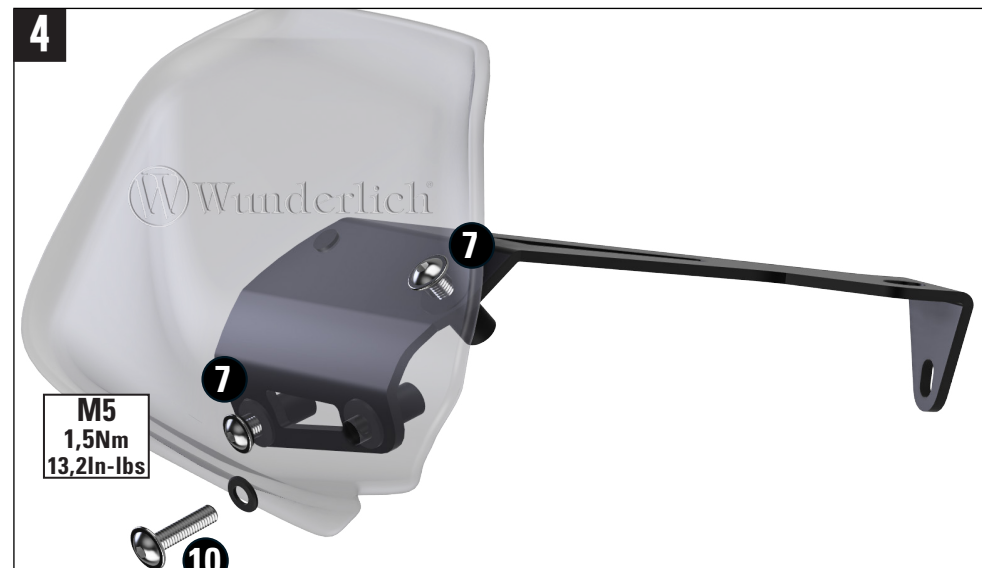

**Handprotectoren vormontieren.**  
*Preassemble hand protectors.*  
*Pré-assembler les protections des mains.*



5

**Markierte Schraube lösen.**

*Loosen the marked screw.  
Desserrez la vis marquée.*

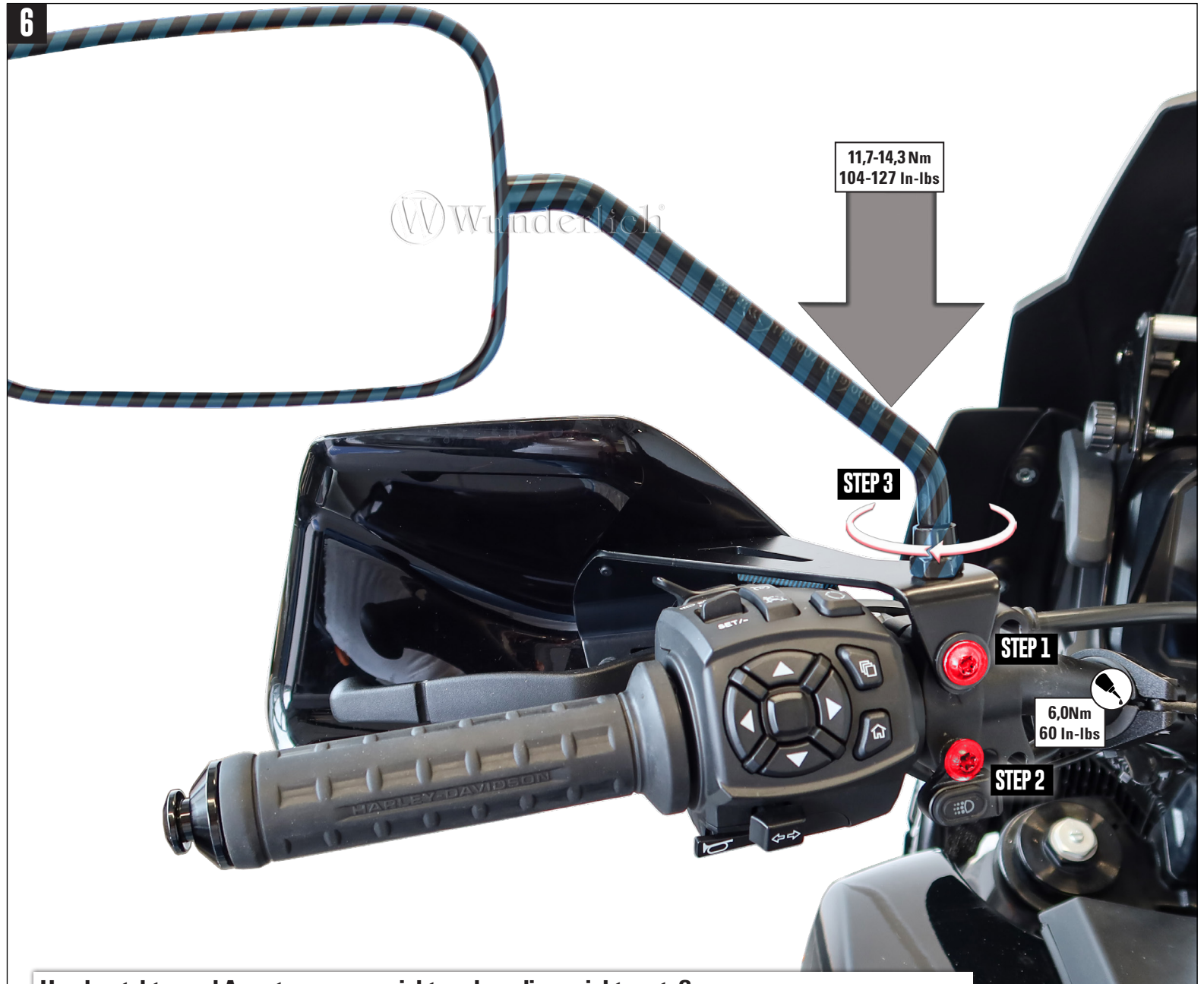

6

11,7-14,3 Nm  
104-127 In-lbs

STEP 3

STEP 1

6,0Nm  
60 In-lbs

STEP 2

**Handprotector und Armaturen so ausrichten, dass diese nicht anstoßen.**

*Align the hand protector and switch fittings so that they do not bump against each other.*

*Alignez le protecteur de la main et les raccords de l'interrupteur de manière à ce qu'ils ne se heurtent pas l'un à l'autre.*