

FLOWJET

Art.-Nr: 90152-00x



Management System
Verifiziert gemäß
genehmigungs-
relevanter
Anforderungen



www.tuv.com
ID 9000012000

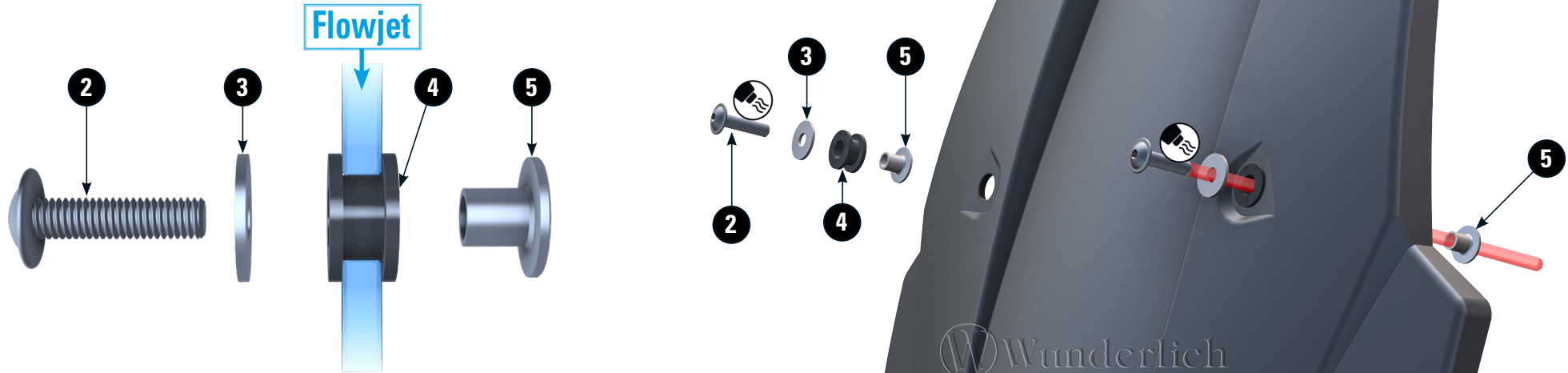

LEGENDE/KEY/FILE LÉGENDE

- Anbau Tipp**
Fitting tip
Astuce de montage
- Achtung**
Attention
Attention
- Vergößerung**
Magnification
Grossissement
- Montagepaste**
Fitting lubricant
Lubrifiant de montage
- Schraube**
Screw
Vis
- Schraubensicherung**
Thread locking fluid
Freinfilets
- | |
|----|
| M |
| Nm |

Drehmoment
Torque
Torque
- Reiniger**
Cleaner
Nettoyant

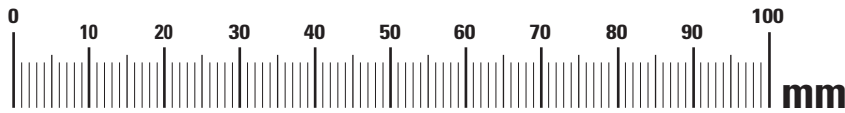

#	BEZEICHNUNG / DESCRIPTION DE / EN / FR	Die Farben der Abbildungen dienen nur der Veranschaulichung. The colors are for illustrating purposes only. Les couleurs utilisées sont à titre indicatif seulement.			DIN	ISO	MENGE QUANTITY
1	Flowjet						1
2	Linsenflanschschraube / lens head screw	M5x20			7381SA2	7381SA2	4
3	U-Scheibe / washer	M5			9021SA2	7093	4
4	Gummitülle / rubber grommet						4
5	Hülse / sleeve						4

Wunderlich

01



02



M5x20
2,5-3,3Nm
22-29 in-lbs



02

