









# LENKERERHÖHUNG

Handlebar risers | Rehausse de guidon | Alzas maniollar | Riser manubrio

Art.-Nr: **71301-00X**



## LEGENDE/KEY/FILE LEGENDE

-  **Anbau Tipp**  
Fitting tip  
Astuce de montage
-  **Achtung**  
Attention  
Attention
-  **Vergößerung**  
Magnification  
Grossissement
-  **Montagepaste**  
Fitting lubricant  
Lubrifiant de montage
-  **Schraube**  
Screw  
Vis
-  **Schraubensicherung**  
Thread locking fluid  
Freinfilets
-  **Drehmoment**  
Torque  
Torque
-  **Reiniger**  
Cleaner  
Nettoyant

#	BEZEICHNUNG / DESCRIPTION	DE EN FR	Die Farben der Abbildungen dienen nur der Veranschaulichung. The colors are for illustrating purposes only. Les couleurs utilisées sont à titre indicatif seulement.			DIN	ISO	MENGE QUANTITY
1	Lenkererhöhung (links) / handlebar riser (left side)							1
2	Lenkererhöhung (rechts) / handlebar riser (right side)							1
3	Zylinderkopfschraube / cylinder head screw		M8x55 lx10.9	25Nm	9612ZNNI	14580ZNNI		4
4	Schraubensicherung / thread locking fluid							1



30.04.25



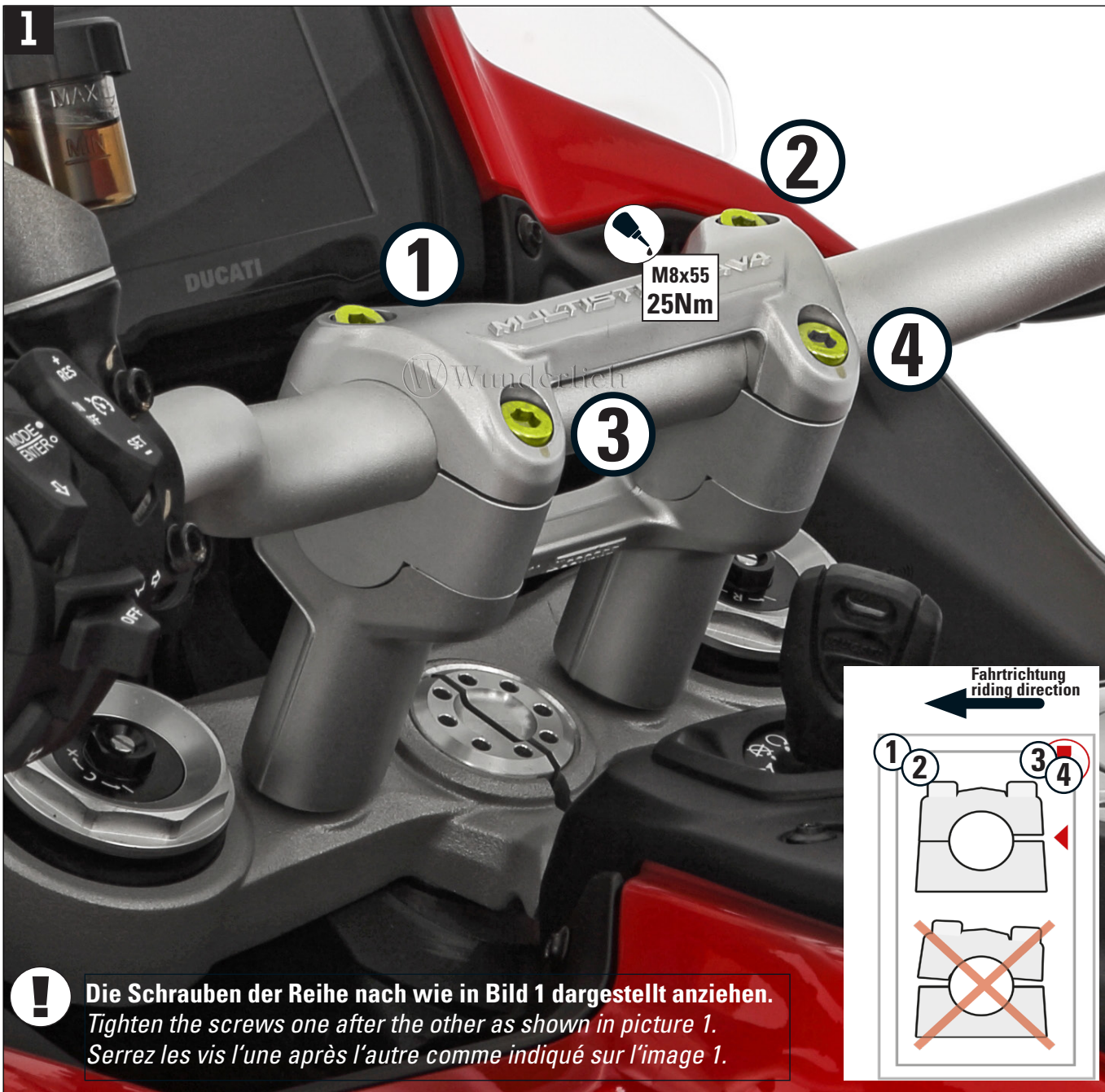

**Die Schrauben der Reihe nach wie in Bild 1 dargestellt anziehen.**  
*Tighten the screws one after the other as shown in picture 1.*  
*Serrez les vis l'une après l'autre comme indiqué sur l'image 1.*

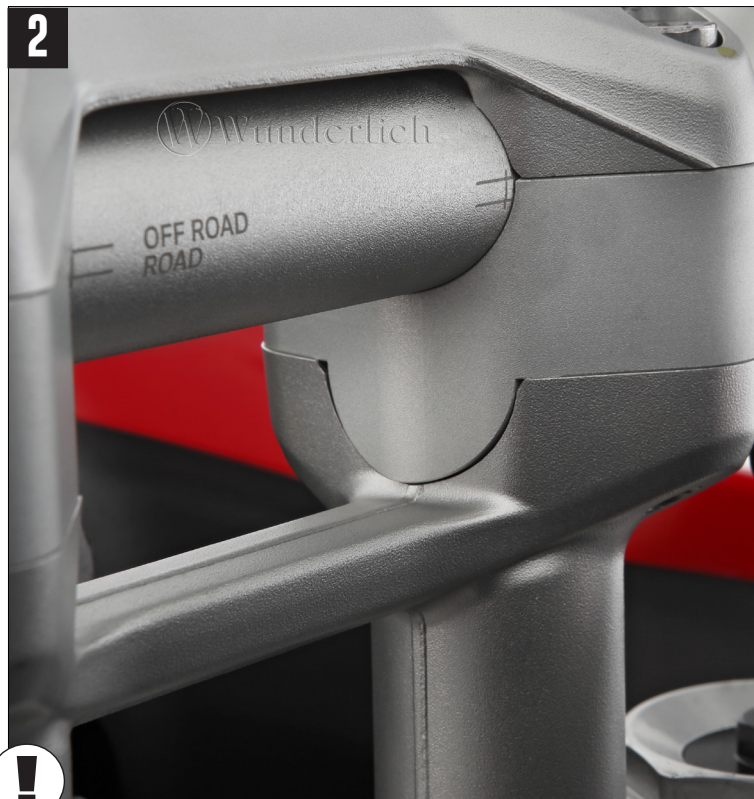
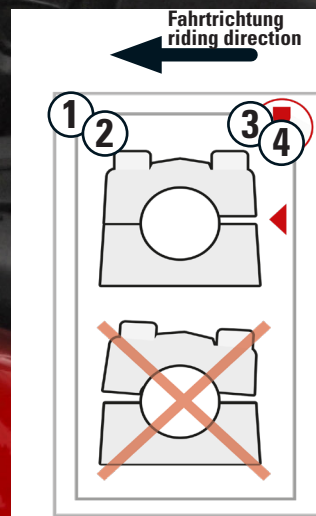

**Leitungen auf freigängigkeit prüfen. Lenkerposition OFF ROAD oder ROAD beachten.**

*Check the lines for free movement. Note the OFF ROAD or ROAD handlebar position.*

*Vérifier que les suspentes se déplacent librement. Notez la position du guidon OFF ROAD ou ROAD.*