

BREMSPUMPENSCHUTZ

Brake cylinder guard | Protection de pompe de frein | Protección para bomba de freno | Protezione per pompe freno

Art.-Nr: 71010-002

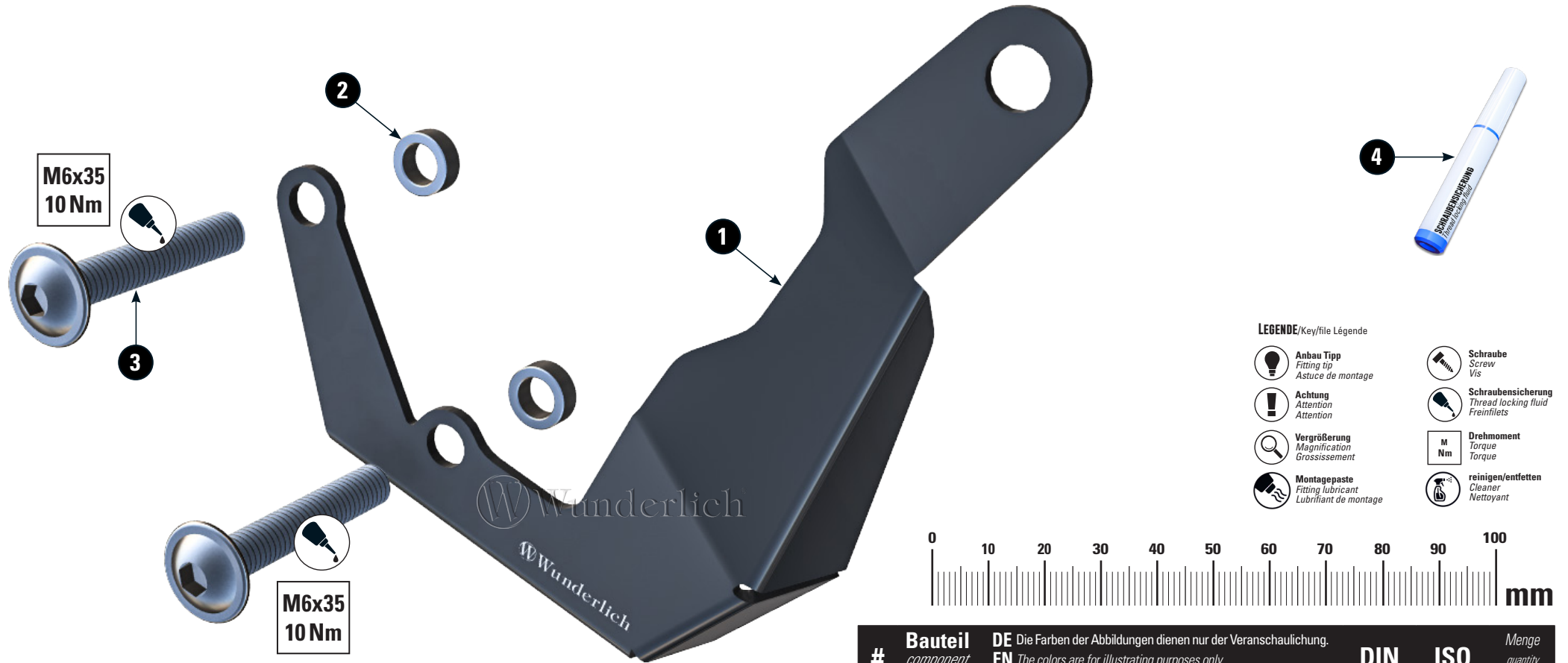

- LEGENDE/Key/file Légende**
- Anbau Tipp**
Fitting tip
Astuce de montage
 - Achtung**
Attention
Attention
 - Vergrößerung**
Magnification
Grossissement
 - Montagepaste**
Fitting lubricant
Lubrifiant de montage
 - Schraube**
Screw
Vis
 - Schraubensicherung**
Thread locking fluid
Freinfilets
 - Drehmoment**
Torque
Torque
 - reinigen/entfetten**
Cleaner
Nettoyant

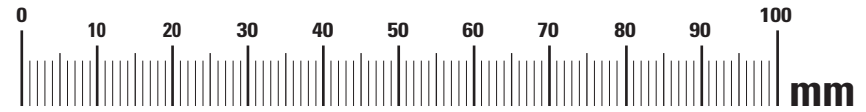

#	Bauteil component composant	DE Die Farben der Abbildungen dienen nur der Veranschaulichung. EN The colors are for illustrating purposes only. FR Les couleurs utilisées sont à titre indicatif seulement.	DIN	ISO	Menge quantity quantité
1	Bremspumpenschutz / Brake cylinder guard				1
2	Linsenflanschschraube / Lens head screw M6x35		7381	7381	2
3	Hülse / Sleeve 4mm				2
4	Schraubensicherung / Thread locking fluid				1



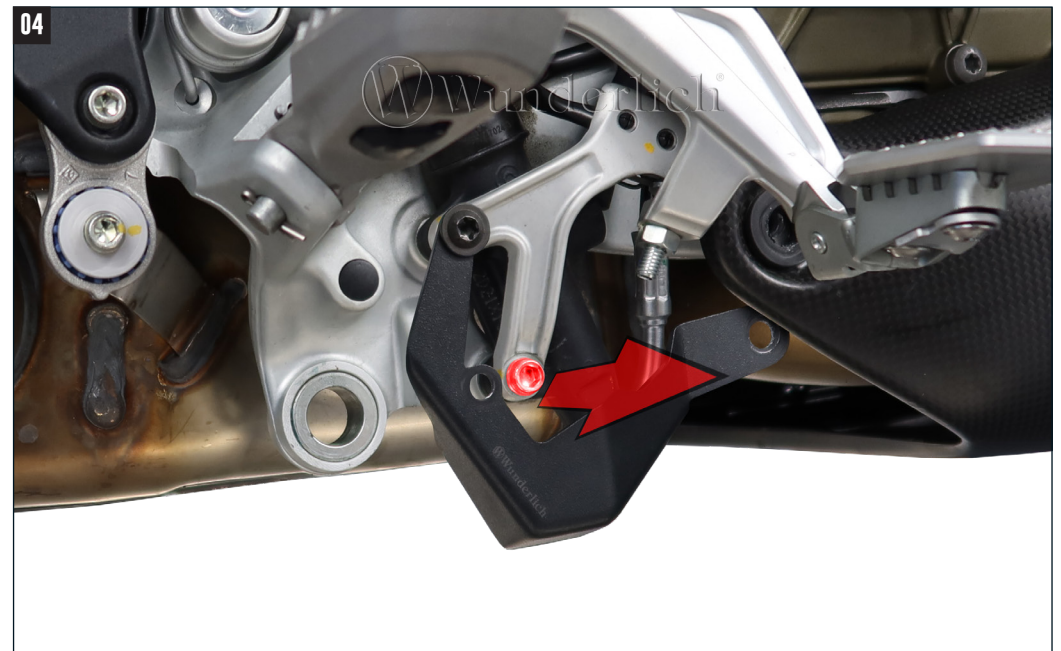
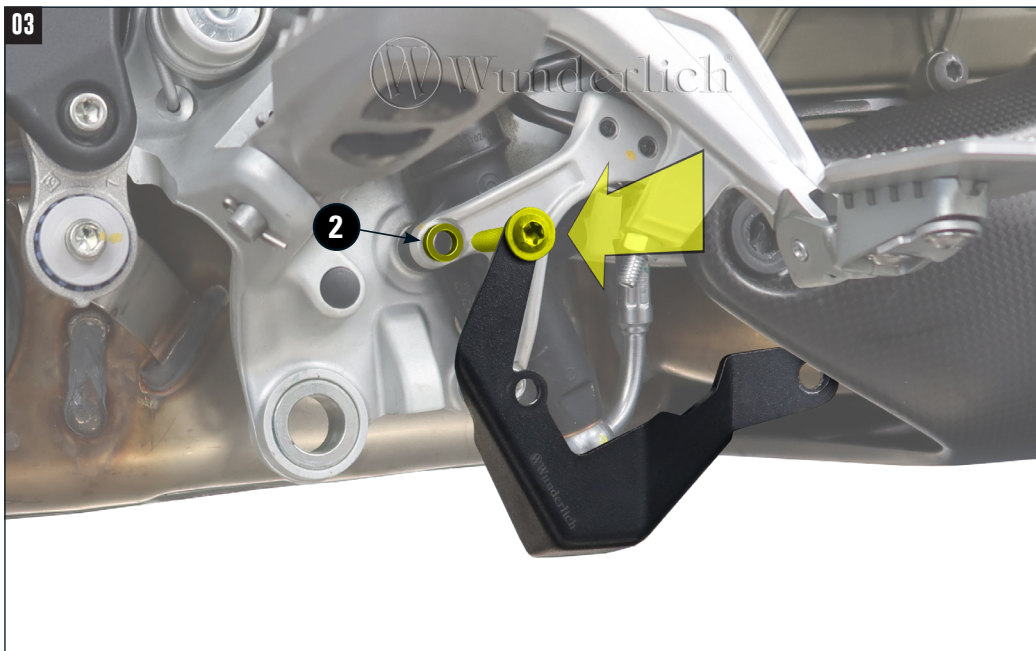
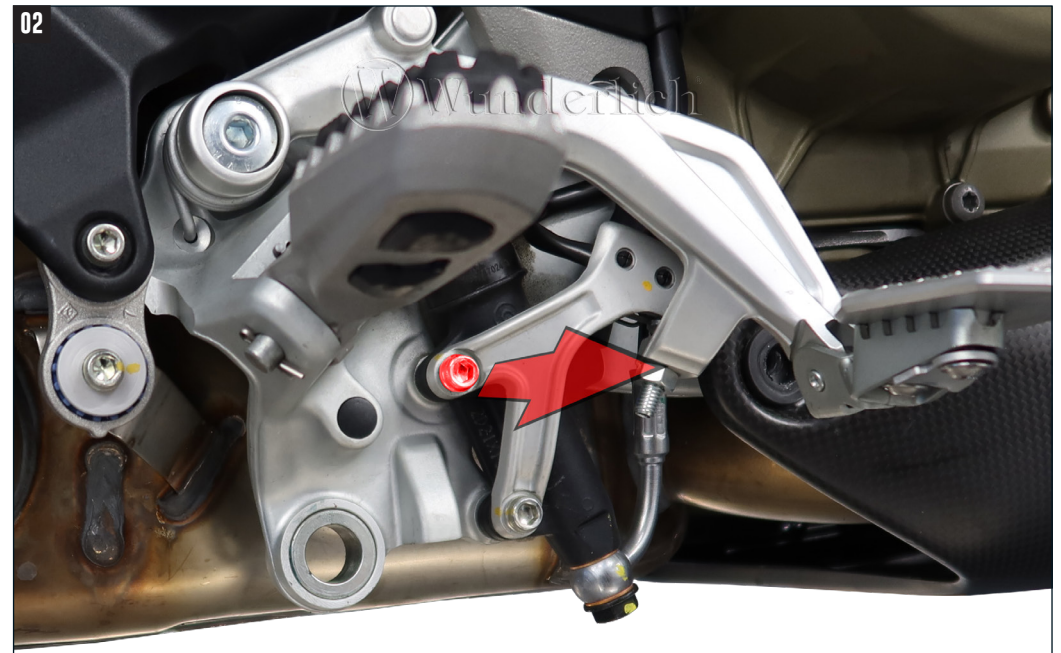

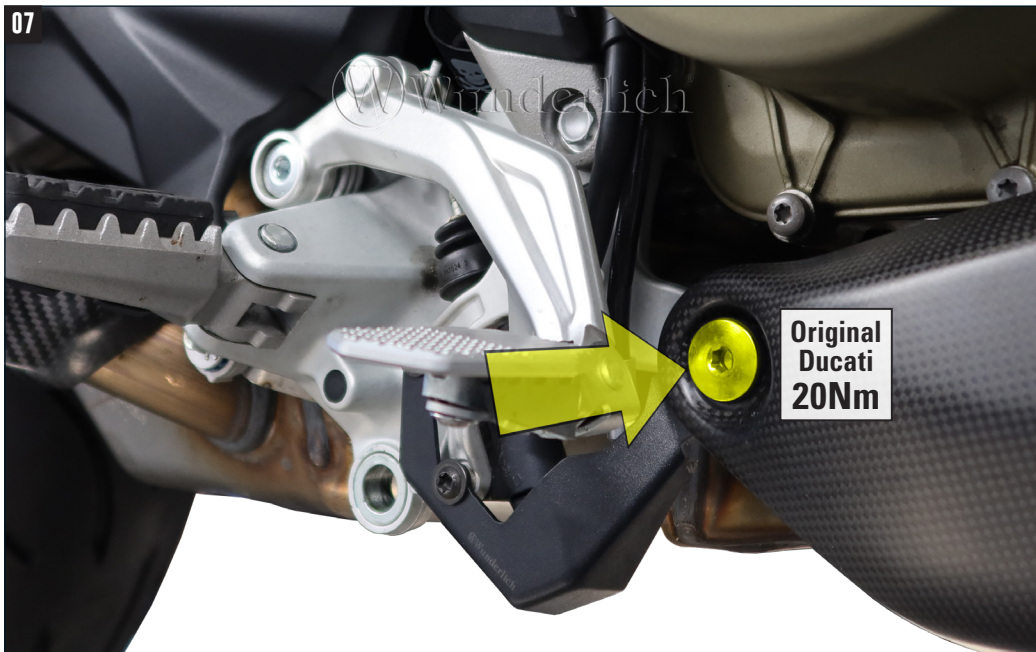
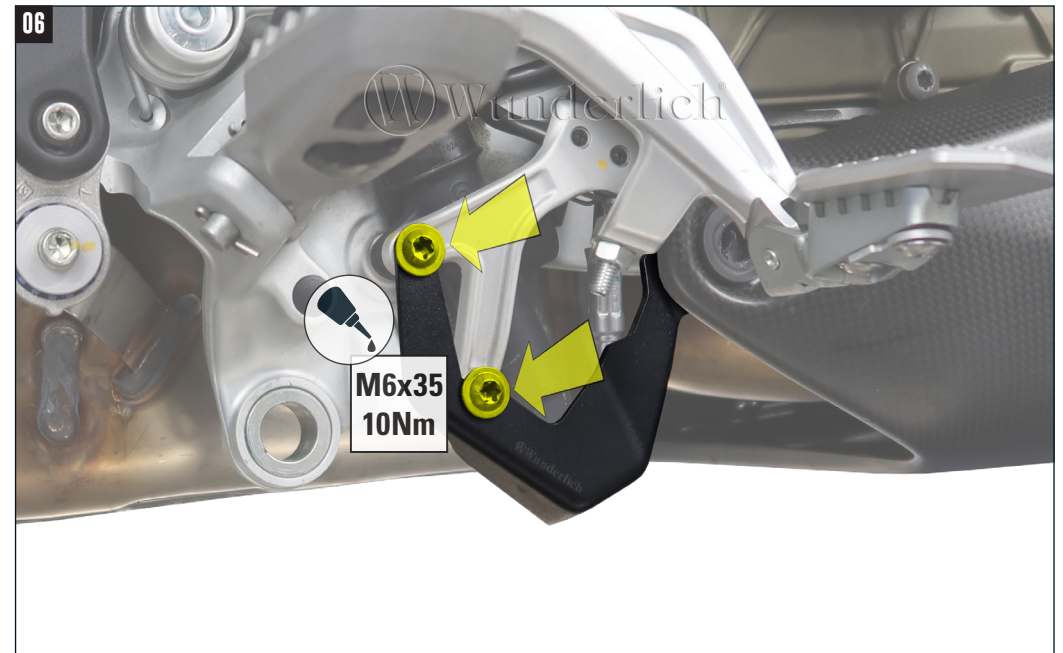

Achten Sie darauf, den Bremslichtschalter nicht zu beschädigen und prüfen Sie nach der Montage seine Funktion.

Make sure not to damage the brake light switch and check its function after assembly.

Veillez à ne pas endommager le commutateur du feu de freinage et vérifiez son fonctionnement après l'assemblage.