

BREMSFLÜSSIGKEITSBEHÄLTERSCHUTZ

Brake reservoir protector | Protection de réservoir de liquide de frein | Protector para el depósito de freno | Protezione serbatoio liquido dei freni

Art.-Nr: 90286-002



Schraube Nr.2 und Mutter Nr.3 werden nur bei Fahrzeugen ohne werksseitig verbauten Handprotektoren benötigt.

Bolt no.2 and nut no.3 are only required for vehicles without factory-fitted hand guards.

Le boulon n°2 et l'écrou n°3 ne sont nécessaires que pour les véhicules sans Protège-mains montés en usine.

LEGENDE/KEY/FILE LÉGENDE

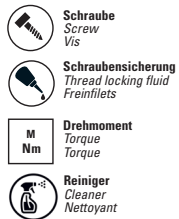
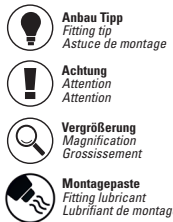

#	BEZEICHNUNG / DESCRIPTION DE / EN / FR	Die Farben der Abbildungen dienen nur der Veranschaulichung. The colors are for illustrating purposes only. Les couleurs utilisées sont à titre indicatif seulement.	DIN	ISO	MENGE QUANTITY
1	Brmsflüssigkeitsbehälterschut / Brake reservoir protector				1
2	Linsenflanschschraube / Lens head screw	M6x20	7381SA2	7381SA2	1
3	Sechskantmutter / hexagon nut	M6	985SA2		1

M6x20
7-9 Nm
62-80 in-lbs

