





# SCHEIBENVERSTÄRKUNG

Windshield stabilizer | Stabilizzator per Parabrezza | Stabilisateur de Pare-brise | Estabilizador de Parabrisas

Art. Nr.: 90157-002

## LEGENDE/Key/file Légende

-  **Anbau Tipp**  
Fitting tip  
Astuce de montage
-  **Achtung**  
Attention  
Attention
-  **Vergrößerung**  
Magnification  
Grossissement
-  **Montagepaste**  
Fitting lubricant  
Lubrifiant de montage

-  **Schraube**  
Screw  
Vis
-  **Schraubensicherung**  
Thread locking fluid  
Freintilts
-  **Drehmoment**  
Torque  
Torque
-  **Reiniger**  
Cleaner  
Nettoyant

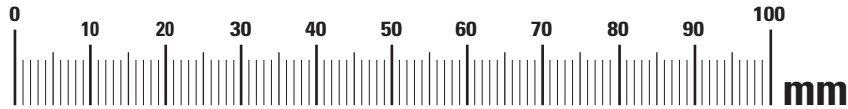
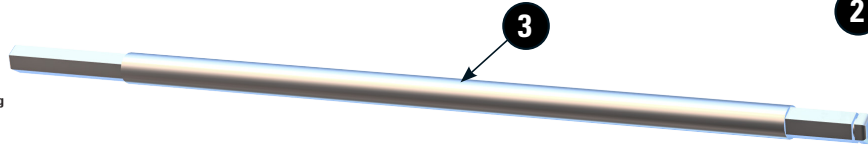

#	BEZEICHNUNG / DE DESCRIPTION	Die Farben der Abbildungen dienen nur der Veranschaulichung. The colors are for illustrating purposes only. Les couleurs utilisées sont à titre indicatif seulement.	DIN	ISO	MENGE QUANTITY
1	Basishalter / base bracketed				1
2	Scheibenhalter / windshield bracketed				1
3	Welle Scheibenverstellung / windshield adjustment shaft				1
4	Bolzen / pin				1
5	Sicherungsscheibe / lock washer	6799			1
6	Sechskantmutter / hexagon nut M6	985	10511		1
7	Rändelschraube / knurled screw M6				1
8	Linsenflanschschraube / lens head screw M5x20	7381	7381		1
9	Hülse / sleeve D=8,5 d=5,5 3mm (M5)				1
10	U-Scheibe / washer M5	9021	7093		1
11	Sechskantmutter / hexagon nut M5	985	10511		1
12	Linsenflanschschraube / lens head screw M6x25	7381	7381		2
13	Hülse / sleeve D=12 d=6,2 3mm (M6)				2
14	Bordsteckdose / socket (Optional) Art.Nr.: 39811-000				1
15	Hülse / sleeve 20mm				1
16	Schraubensicherung / Thread locking fluid				1

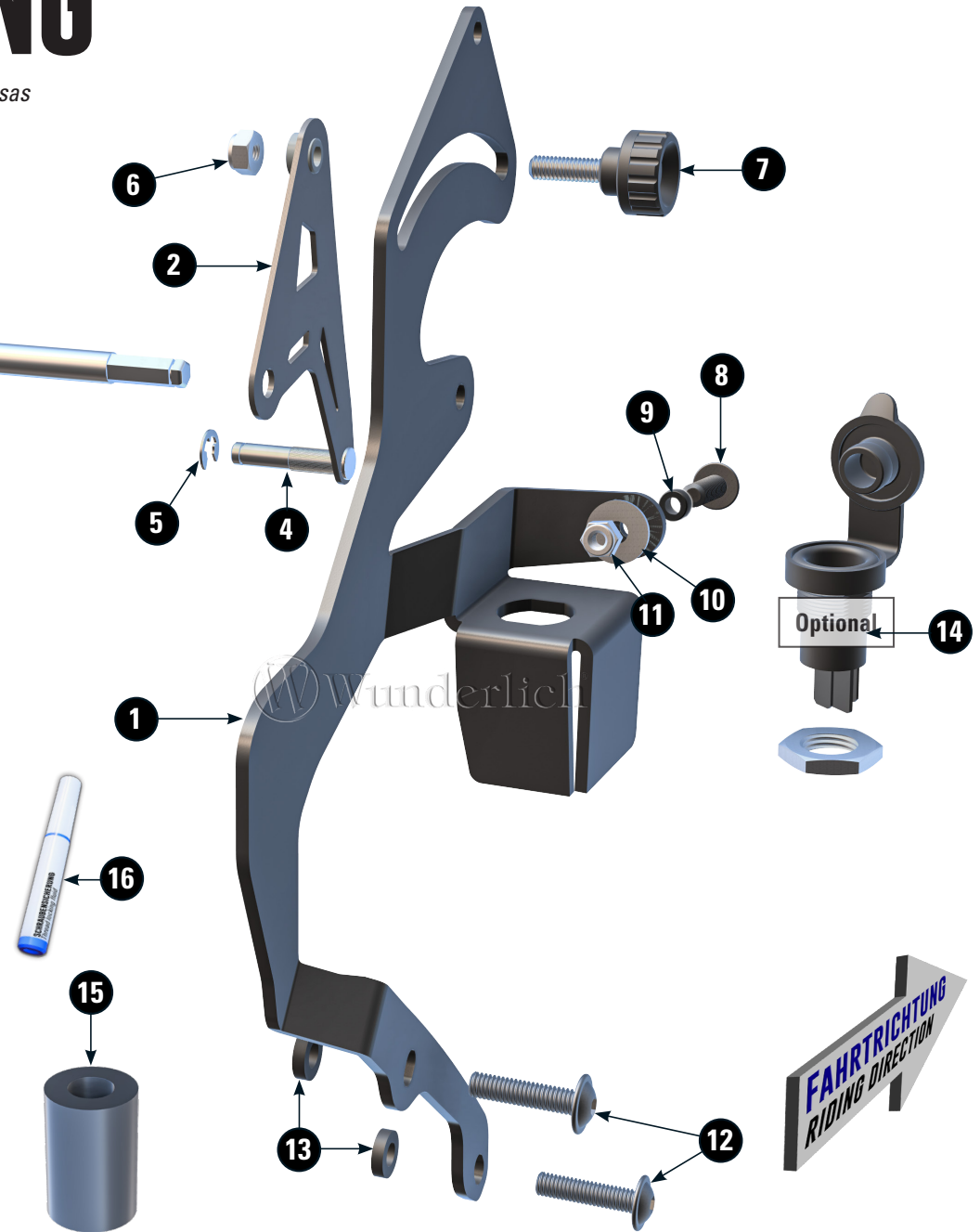

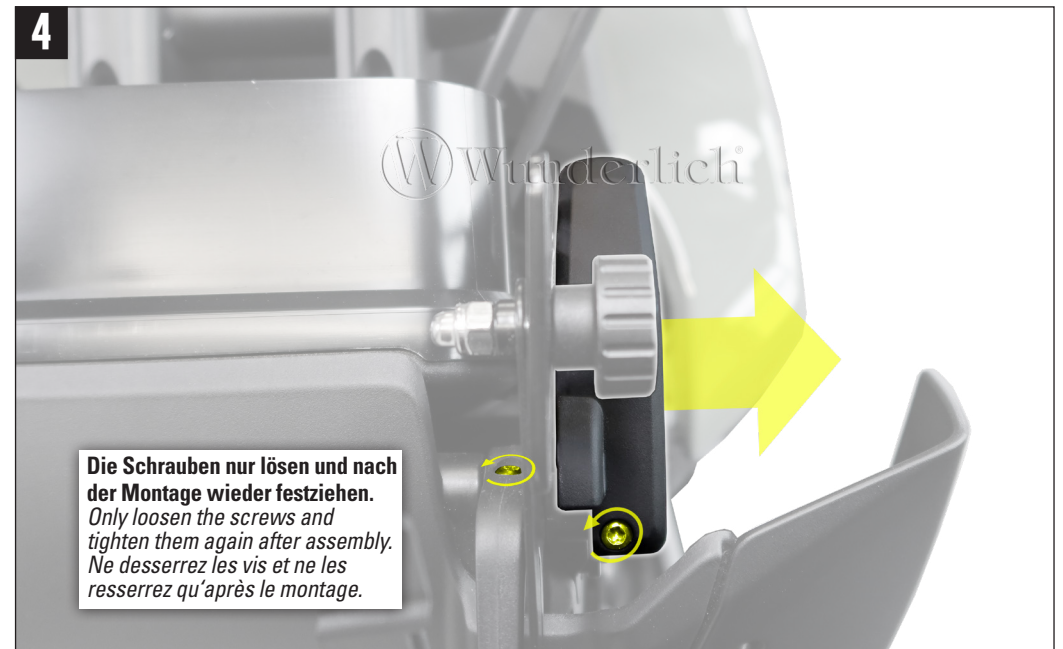
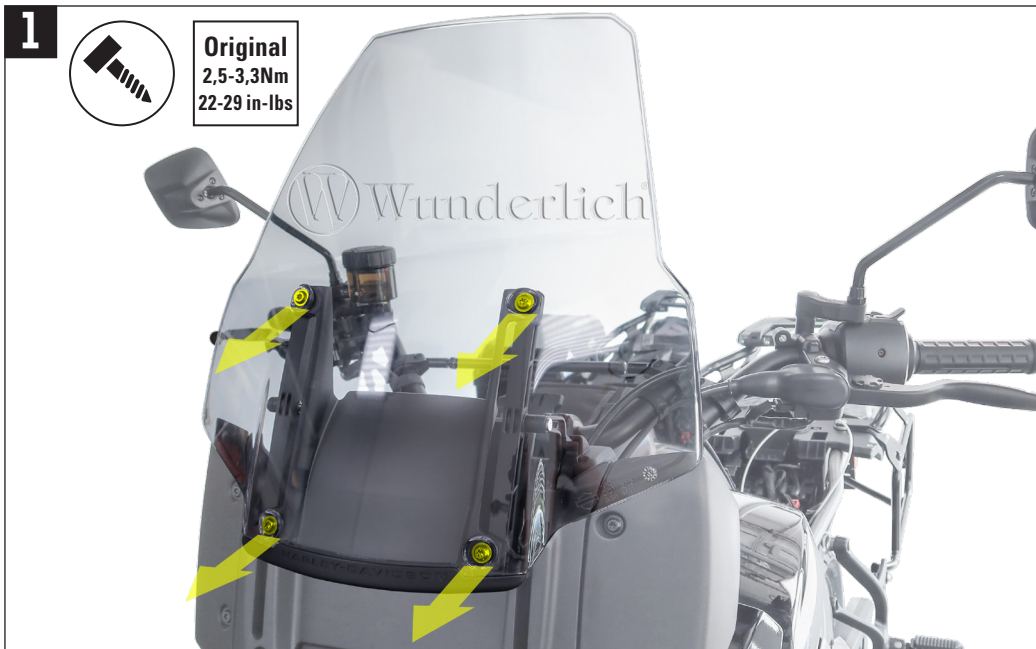

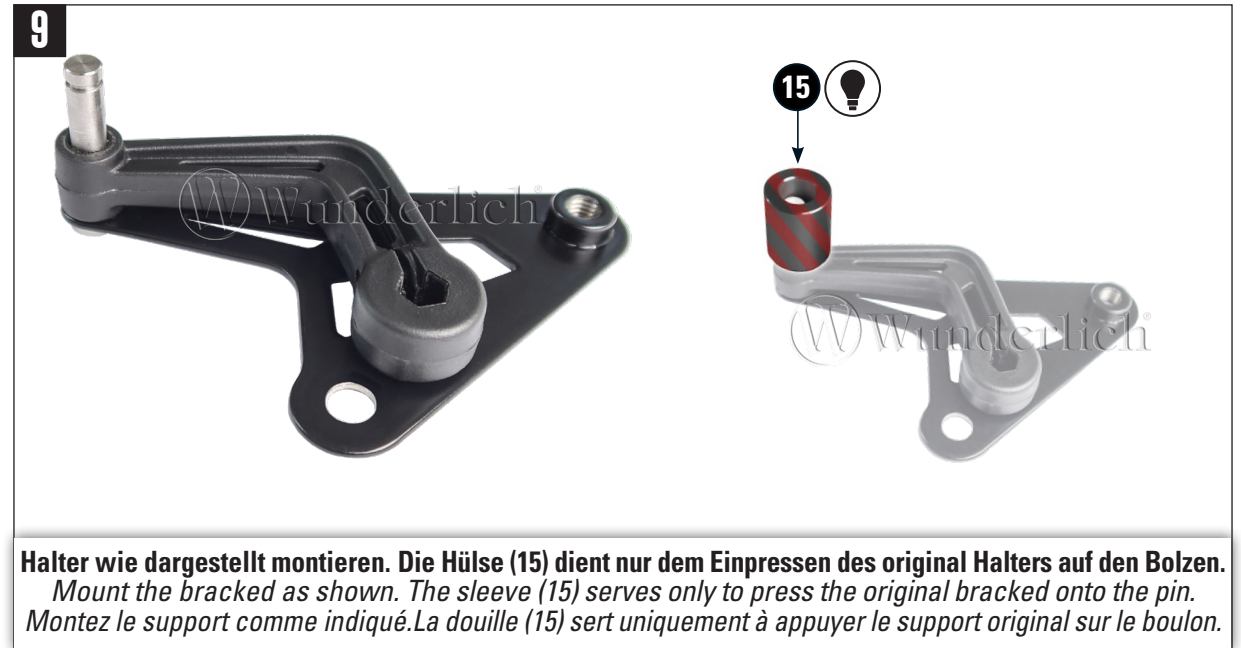
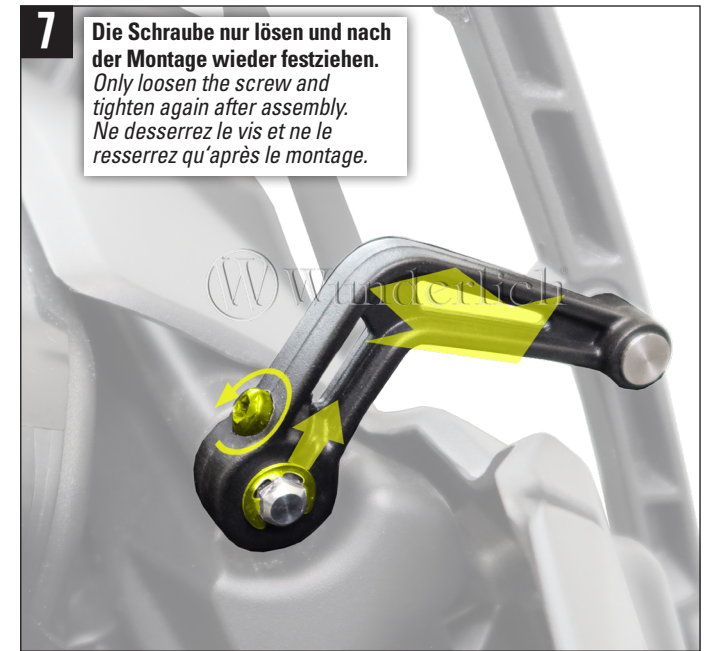

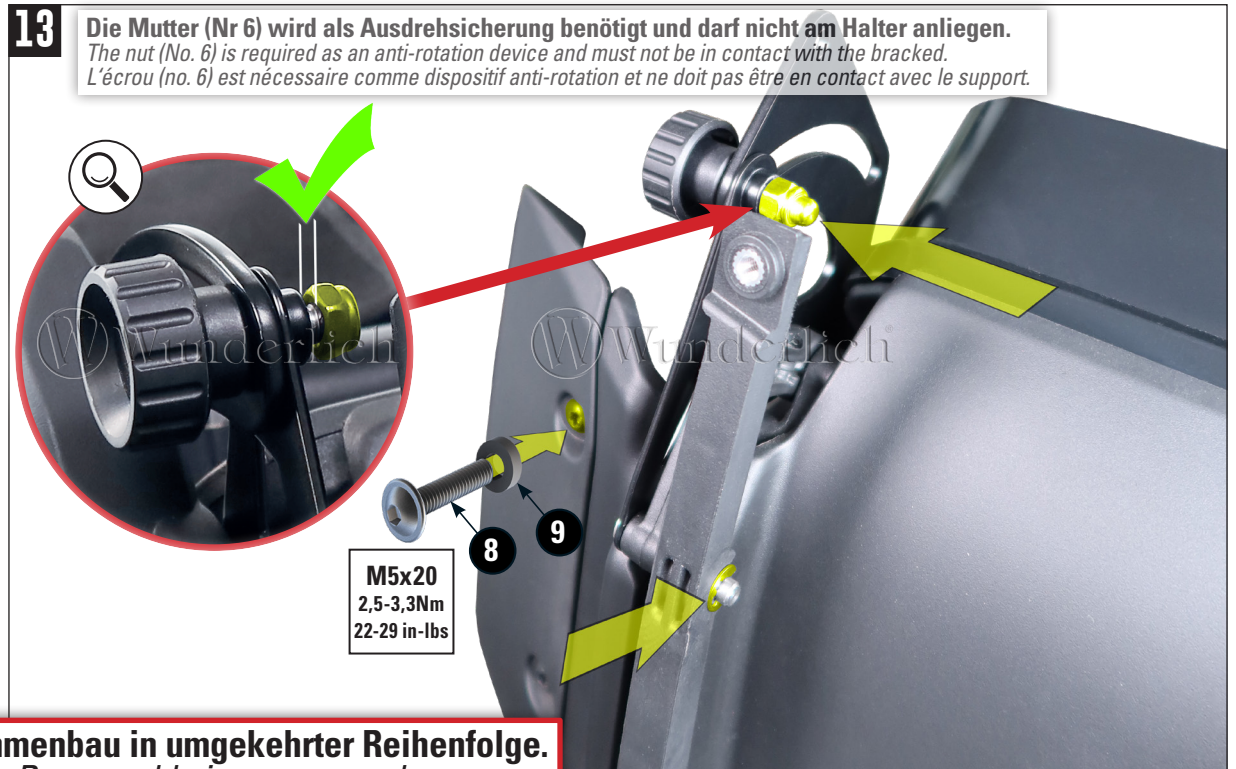
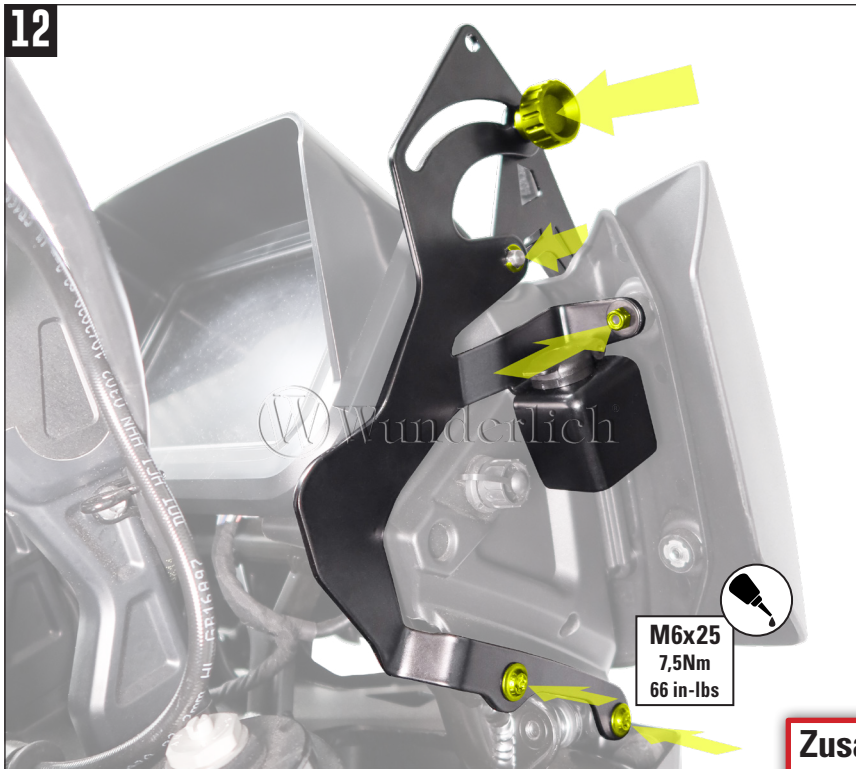
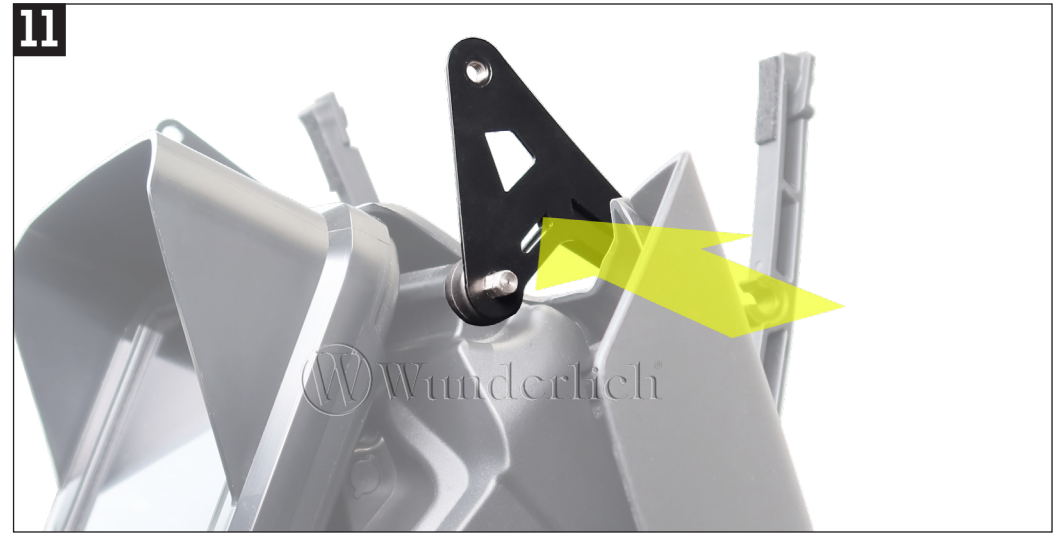

**Zusammenbau in umgekehrter Reihenfolge.**  
*Reassemble in reverse order.*  
*Remontez dans l'ordre inverse.*