

BREMS-/ KUPPLUNGSLEITUNGSVERLEGUNG





brake line relocation adapter | adaptateur de relocalisation de la ligne de freinage | adaptador de reubicación del latiguillo de freno | adattatore per il riposizionamento dei tubi dei freni

Art.-Nr: 31002-20X



LEGENDE/KEY/FILE LÉGENDE

-  **Anbau Tipp**
Fitting tip
Astuce de montage
-  **Achtung**
Attention
Attention
-  **Vergrößerung**
Magnification
Grossissement
-  **Montagepaste**
Fitting lubricant
Lubrifiant de montage

-  **Schraube**
Screw
Vis
-  **Schraubensicherung**
Thread locking fluid
Freinfilets
-  **Drehmoment**
Torque
Torque
-  **reinigen/entfetten**
Cleaner
Nettoyant

#	BEZEICHNUNG / DESCRIPTION	DE EN	FR	DIN	ISO	MENGE QUANTITY
1	Bremsleitungsverlegung / brake line relocation adapter					1
2	Hohlschraube / banjo bolt					1
3	Kupferdichtring / copper sealing ring					4
4	Verbunddichtring / composite sealing ring					2

Die Farben der Abbildungen dienen nur der Veranschaulichung.
The colors are for illustrating purposes only.
Les couleurs utilisées sont à titre indicatif seulement.

1

BREMSARMATUR
Brake assembly
Ensemble de frein

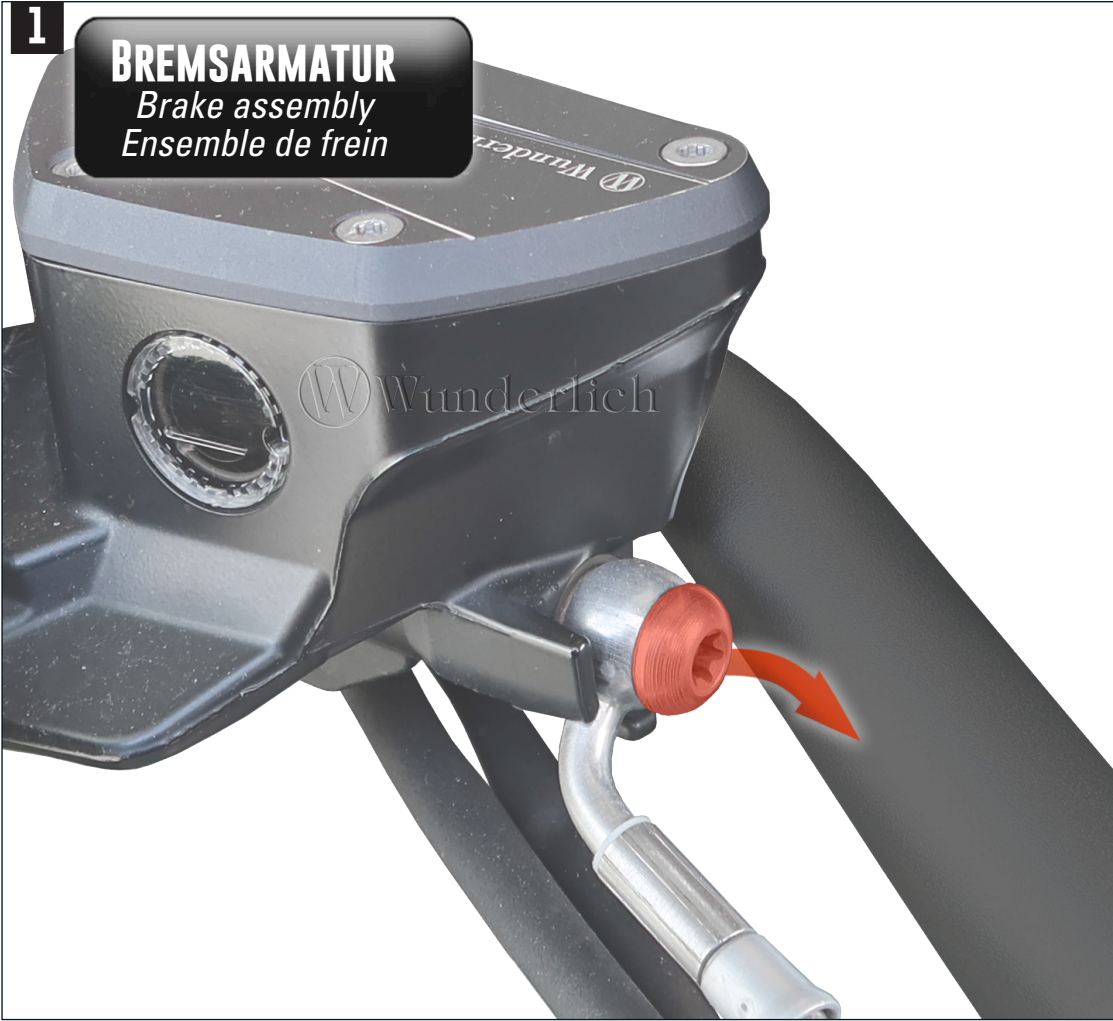

2

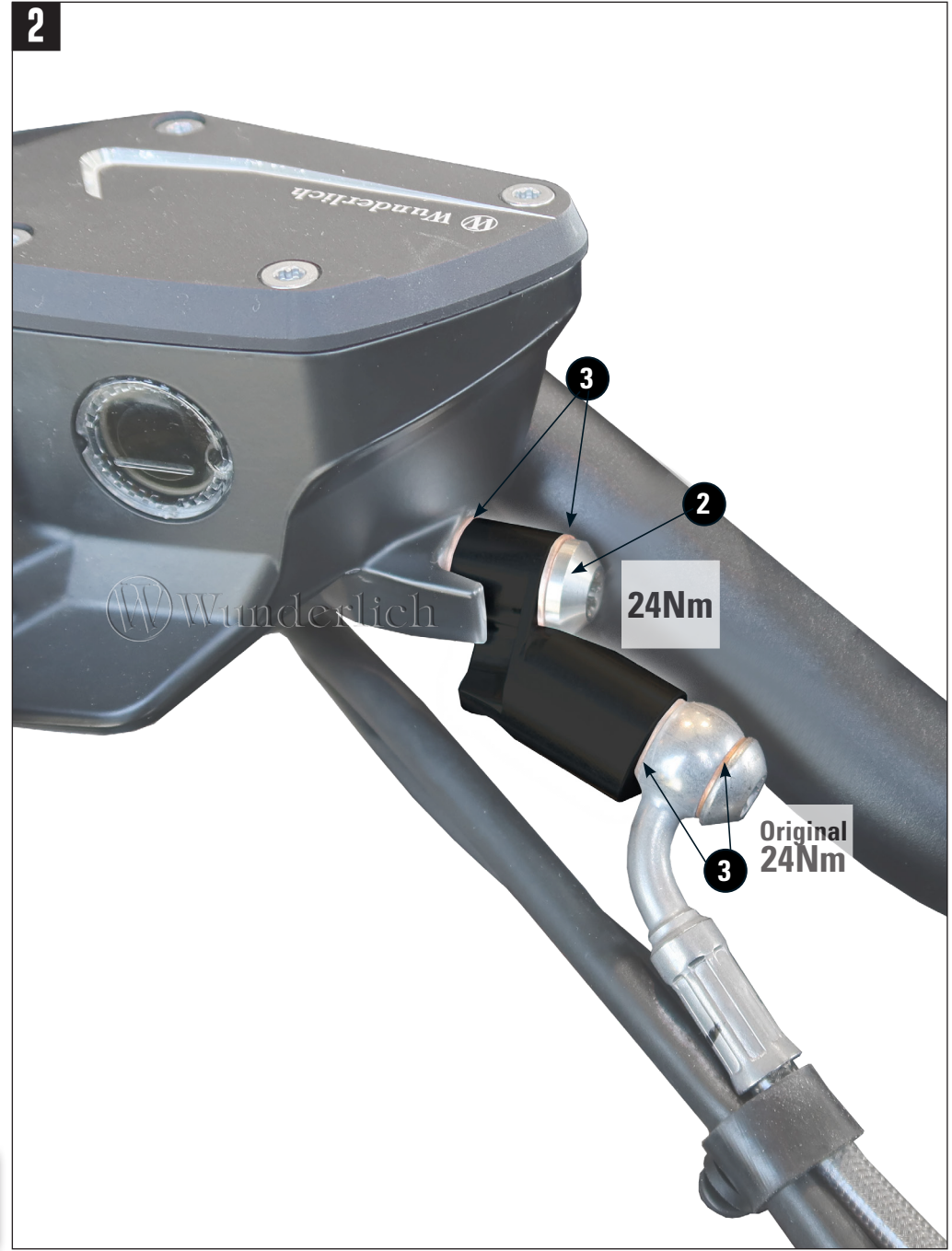

Die Brems- und Kupplungsleitungsadapter montieren und nach Herstellerangaben entlüften.
Install the brake and clutch line adapters and bleed them according to the manufacturer's instructions.
Monter les adaptateurs de conduites de frein et d'embrayage et les purger selon les indications du fabricant.

3.1

Kupplungsarmatur mit 2xO-Ringen
Clutch assembly with 2xO-rings
Ensemble d'embrayage avec 2x joints toriques



3.2

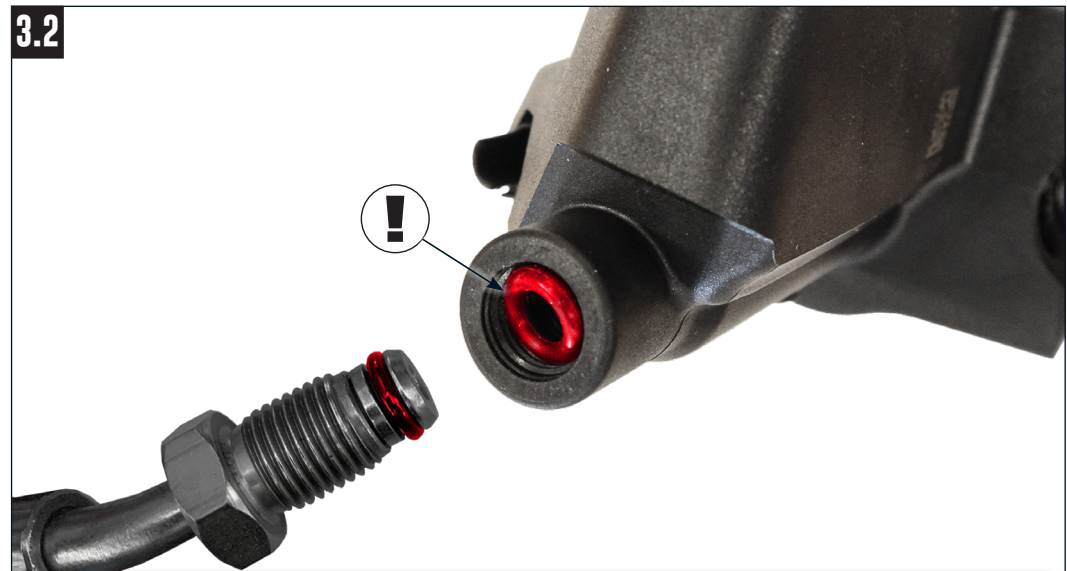

Baustand bedingt kann original noch ein zweiter O-Ring verbaut sein. Diesen dann auch mit Systemflüssigkeit benetzen und wie gezeigt wieder einsetzen.

Depending on the assembly status, a second O-ring may still be installed. Moisten this O-ring with system fluid as well and reinstall it as shown.

Selon l'état du montage, un deuxième joint torique peut encore être en place. Humidifiez également ce joint torique avec le fluide du système, puis remettez-le en place comme indiqué.

3.3

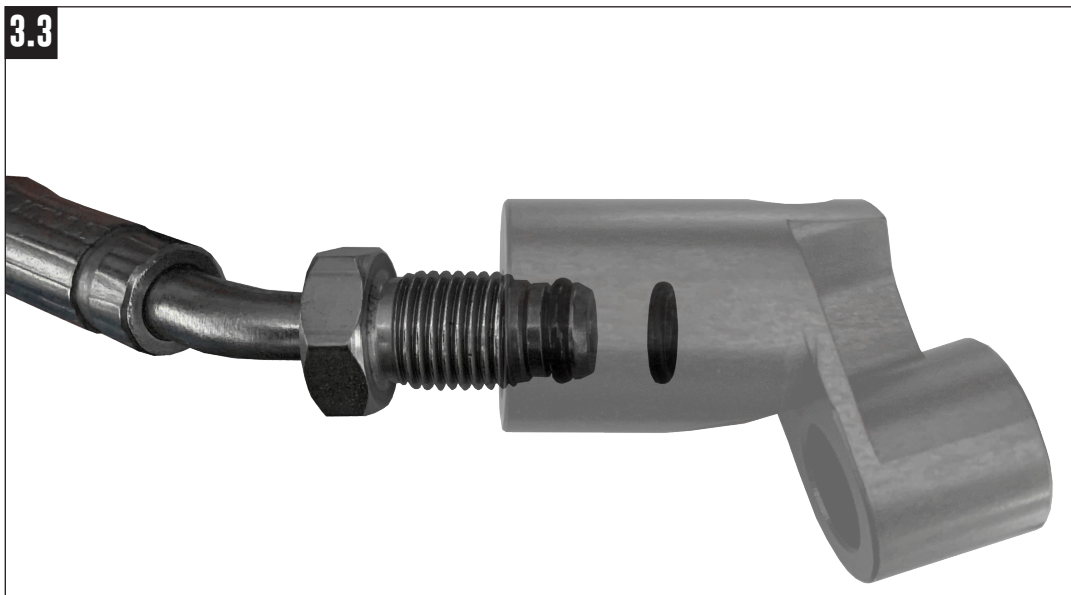

3.4

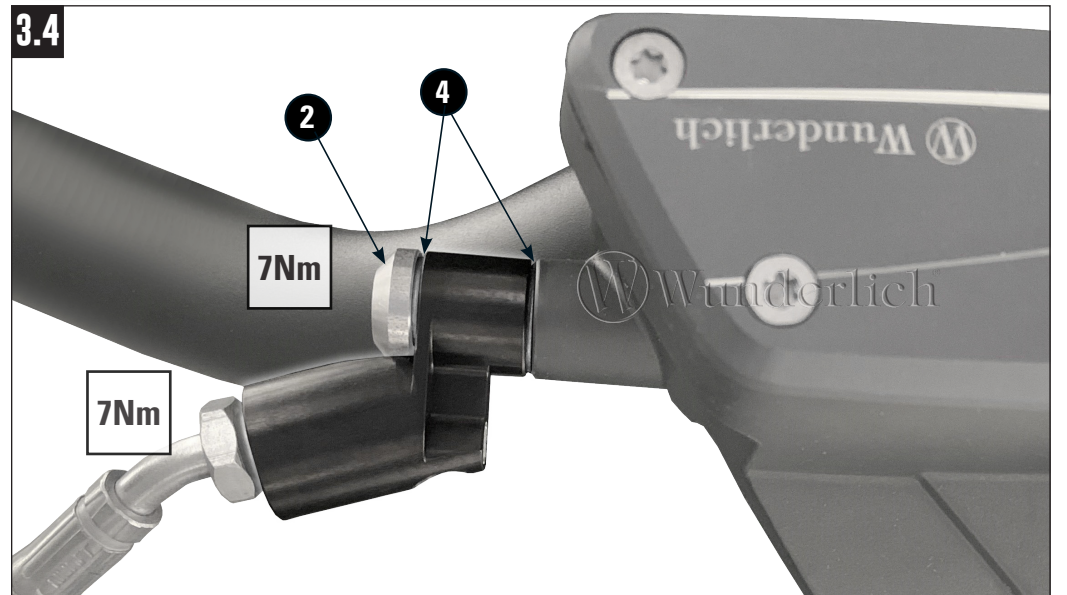

4.1

Kupplungsarmatur mit 1x O-Ring
Clutch assembly with 1x O-ring
Ensemble d'embrayage avec 1x joint torique



4.2

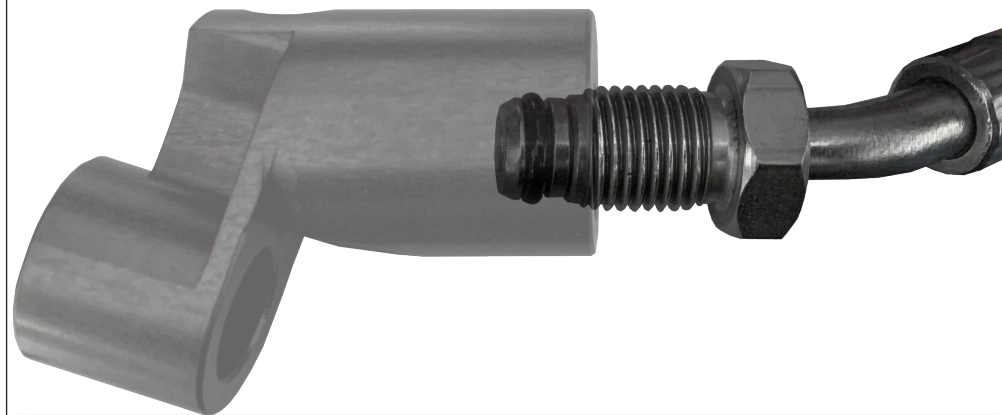

O-Ring mit Systemflüssigkeit benetzen und wie gezeigt wieder einsetzen.
Moisten the O-ring with the system fluid and reinstall it as shown.
Humidifiez le joint torique avec le fluide du système, puis remettez-le en place comme indiqué.

4.3

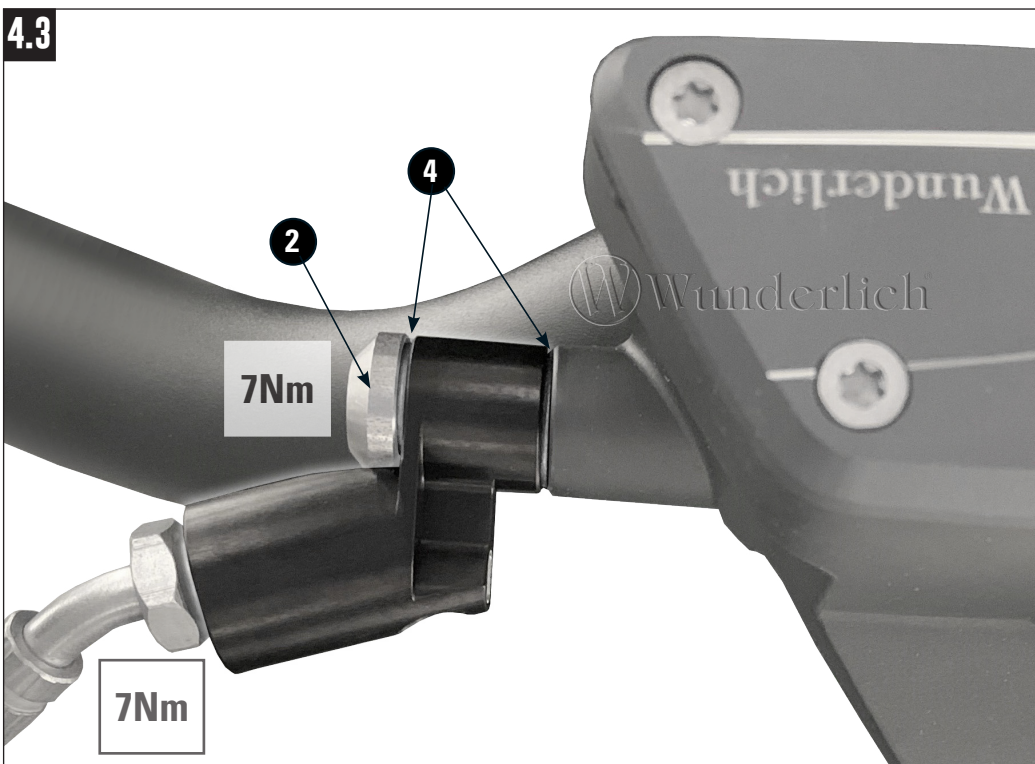

Die Brems.- und Kupplungsleitungsadapter montieren und nach Herstellerangaben entlüften.
Install the brake and clutch line adapters and bleed them according to the manufacturer's instructions.
Monter les adaptateurs de conduites de frein et d'embrayage et les purger selon les indications du fabricant.