

# STURZBÜGEL FUSSRASTEN

Crash bar foot rests | Estriberas para la barra de protección | Pedane posapiedi sul paracilindri | Repose-pieds de la barre de chocs

**Nicht im Straßenverkehr zugelassen (StVZO) | Not allowed in road traffic (StVZO)**

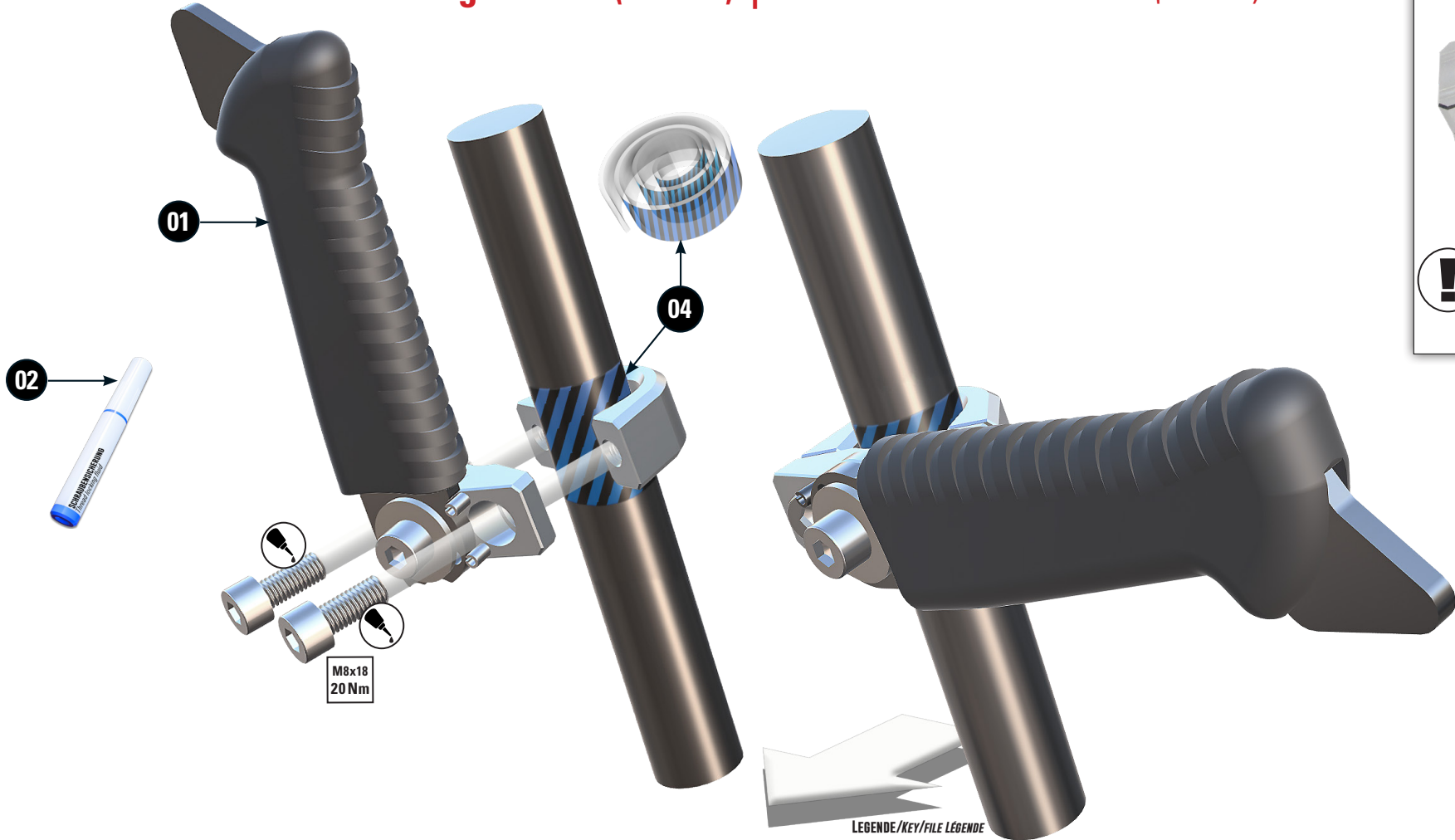

LEGENDE/KEY/FILE LÉGENDE

#	BEZEICHNUNG / DESCRIPTION	DE EN FR	DIN	ISO	MENGE QUANTITY
1	Fussraste vormontiert (links- rechts) / Foot rests pre-assembled (left and right side)	Die Farben der Abbildungen dienen nur der Veranschaulichung. The colors are for illustrating purposes only. Les couleurs utilisées sont à titre indicatif seulement.			2
2	Schraubensicherung / Thread locking fluid				1
3	Montagepaste / Fitting lubricant				1
4	Lackschutzfolie / Paint protection film				20 cm

- Anbau Tipp**  
Fitting tip  
Astuce de montage
- Achtung**  
Attention  
Attention
- Vergrößerung**  
Magnification  
Grossissement
- Montagepaste**  
Fitting lubricant  
Lubrifiant de montage
- Schraube**  
Screw  
Vis
- Schraubensicherung**  
Thread locking fluid  
Freinfilets
- Drehmoment**  
Torque  
Torque
- Reiniger**  
Cleaner  
Nettoyant

1.1

**ANBAUBEISPIEL 1**  
*Mounting example 1*  
*Exemple de montage 1*



1.2

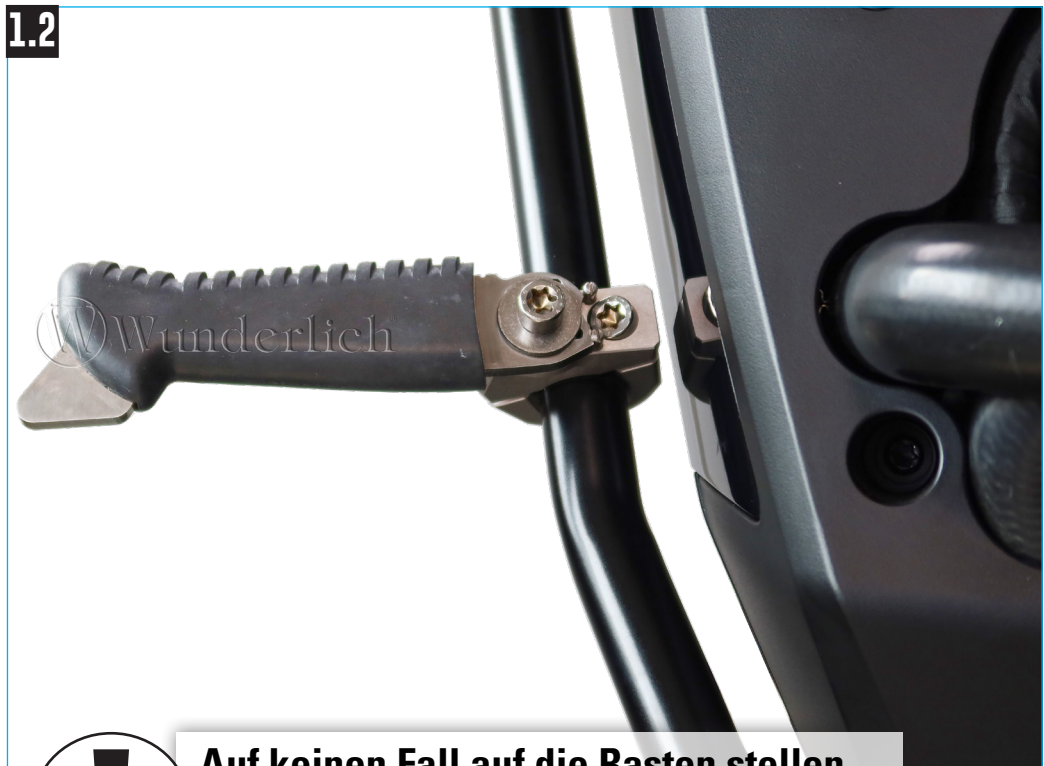

**Auf keinen Fall auf die Rasten stellen.**  
*Never stand on the pegs.*  
*Mai stare sulle spine.*  
*Ne montez jamais sur les chevilles.*  
*Nunca se pare sobre las clavijas.*

2.1

**ANBAUBEISPIEL 2**  
*Mounting example 2*  
*Exemple de montage 2*



2.2



**Auf keinen Fall auf die Rasten stellen.**  
*Never stand on the pegs.*  
*Mai stare sulle spine.*  
*Ne montez jamais sur les chevilles.*  
*Nunca se pare sobre las clavijas.*